

**Question Paper 2015 Outside Delhi set 1
CBSE Class 12 ENGINEERING DRAWING**

General Instructions:

- Attempt all the questions.
- Follow the SP : 46-2003 revised codes (with First Angle method of projection).
- Missing and mismatching dimensions, if any, may be suitably assumed.
- All dimensions are in millimetres.
- Use the given dimensions in figures

1. Answer the following Multiple-Choice Questions. Print the correct choice on your drawing sheet. [5]

(i) Section area is shown by

(a) Sketching (b) Colouring (c) Hatching/section linings (d) Dots

(ii) The end of the Stud which is screwed in the body of casting with threaded hole is called

(a) Nut end (b) Metal end (c) Close end (d) Open end

(iii) In which of the following joints, a single line/row of rivets is used to join two plates together ?

(a) Zigzag joint (b) Single riveted lap joint (c) Double riveted lap joint (d) Multiple riveted joint

(iv) The portion of the shaft which rotates in the sleeve/bush of a bushed bearing is called as

(a) Journal (b) Axle (c) Rod (d) Pipe

(v) Protected flange coupling is better than the unprotected flange coupling with regard to

**(a) Protection from dirt (b) Protection from water (c) Protection from fire hazards
(d) Ensure safety**

Ans. (i) (c) or Hatching/section linings. (ii) (b) or Metal end. (iii) (b) or Single riveted lap joint. (iv) (a) or Journal. (v) (d) or Ensure safety.

2. (i) Construct an isometric scale. [4]

(ii) Draw the isometric projection of a frustum of a hexagonal pyramid (top base edge 30 mm, bottom base edge 40 mm, height 60 mm), keeping its axis perpendicular to H.P. and two of its base sides parallel to V.P. Draw the axis and indicate the direction of viewing. Give all dimensions. [7]

(iii) A right circular cone (base diameter 50 mm, height 50 mm) is placed with its base resting centrally on the top rectangular face of a horizontal triangular prism (side of triangle 40 mm, length of the prism 70 mm), keeping triangular faces of the prism parallel to V.P. Draw the isometric projection of the combination of solids. Show the axis of each solid and indicate the direction of viewing. Give all dimensions. [13]

Ans. (i) ISOMETRIC SCALE

(i) Marking of divisions of 10 mm, including division of first part of mm on true length.

(ii) Projections from scale 1:1 to get points on isometric scale, construction of isometric scale.

(iii) Printing 'True Length/Scale 1:1', 'Isometric Length/Isometric Scale' and marking angles of 30° & 45° .

(ii) ISOMETRIC PROJECTION OF A FRUSTUM OF A HEXAGONAL PYRAMID

(i) Drawing helping figure of both hexagons.

(ii) Drawing isometric hexagon, on top and at the base.

(iii) Drawing four slant edges.

(iv) Marking the vertical axis, direction of viewing.

(v) Dimensions.

NOTE: For incorrect position, 1 mark should be deducted.

(iii) ISOMETRIC PROJECTION OF A CONE PLACED, CENTRALLY, ON A TRIANGULAR PRISM [13]

TRIANGULAR PRISM 7

(i) Drawing helping figure. (ii) Drawing both isometric triangles. (iii) Drawing horizontal edges. (iv) Marking the horizontal axis. (v) Dimensions.

CONE 6

(i) Drawing isometric ellipse along with centre lines. (ii) Drawing both generators. (2) (iii) Marking the vertical axis (1/2) and direction of viewing (1/2). (iv) Dimensions.

3. (i) Draw to scale 1 : 1, the standard profile of a B.S.W. thread, taking enlarged pitch as 40 mm. Give standard dimensions. [8]

OR

Draw to scale 1 : 1, the front view and side view of a Hook bolt of size M20, keeping the axis parallel to V.P and H.P. Give standard dimensions.

(ii) Sketch freehand the front view of a Socket head machine screw of size M20. Keep the axis perpendicular to H.P. Give standard dimensions. [5]

OR

Sketch freehand the front view, top view and side view of a Woodruff key, suitable for a shaft of diameter 60 mm. Give standard dimensions.

Ans. (i) B.S.W. THREAD PROFILE

(i) Horizontal distances (equal to half of pitch), vertical distances ($D=0.96P$, $D/6$) marked correctly.

(ii) Drawing roots and crests of threads (minimum two) and flanks, drawn correctly.

(iii) Drawing hatching lines and conventional break.

(iv) Standard dimensions.

[OR]

HOOK BOLT

FRONT VIEW:

(i) Threaded and unthreaded portions of cylindrical shank with square neck. (ii) Head of bolt.

SIDE VIEW:

(i) Rectangle with one horizontal line. (ii) Two circles as per convention.

Standard dimensions.

(ii) SOCKET HEAD MACHINE SCREW

Front view with its axis perpendicular to H.P.

(i) Drawing the head. (ii) Drawing the shank. (iii) Standard dimensions.

[OR]

WOODRUFF KEY

(i) Front view. (ii) Top view. (iii) Side View. (iv) Standard dimensions.

4. Figure 1 (on page 7) shows the details of the parts of a SLEEVE AND COTTER JOINT.

Assemble these parts correctly, and then draw the following views using scale 1 : 1.

(i) Front view, upper half in section. [14]

(ii) Right hand side view.[8]

Print the title and the scale used. Draw the projection symbol. Give 6 important dimensions.

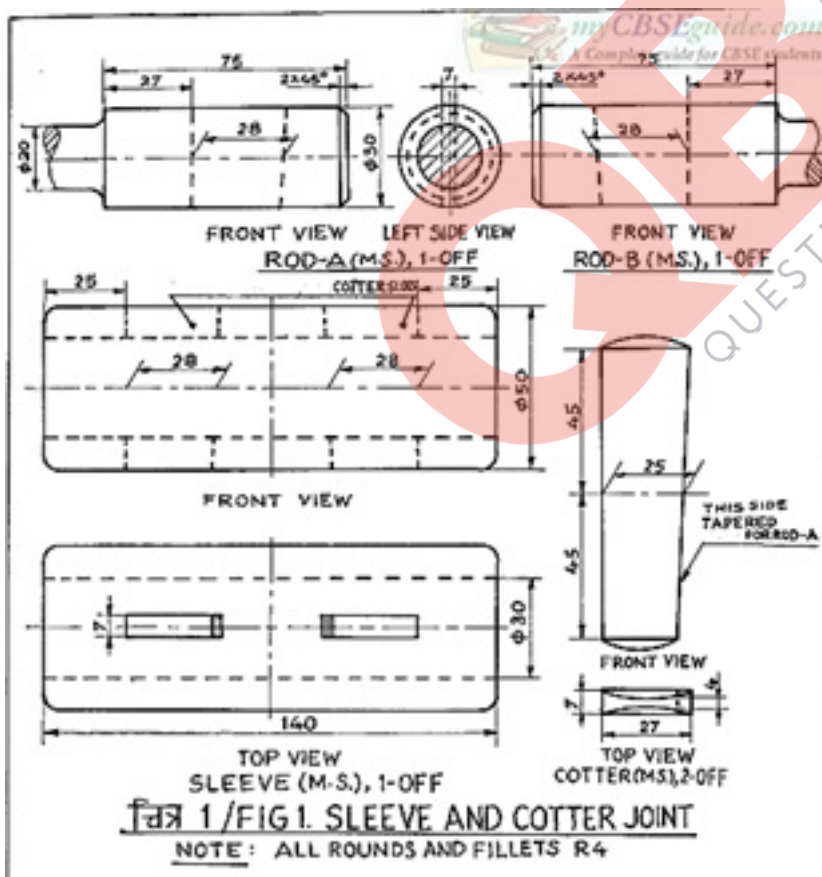

OR

Figure 2 (on page 9) shows the assembly of the parts of a FLANGE PIPE JOINT.

Disassemble the parts and then draw the following views of the following components to scale 1 : 1, keeping them in the same position with respect to H.P. and V.P. [6]

(i) FLANGE B:

(a) Front view, upper half in section.

(b) Right hand side view.

(ii) GASKET:

(a) Full sectional front view.

(b) Left hand side view.

Print the titles of both and the scale used. Draw the projection symbol.

Give 6 important dimensions.

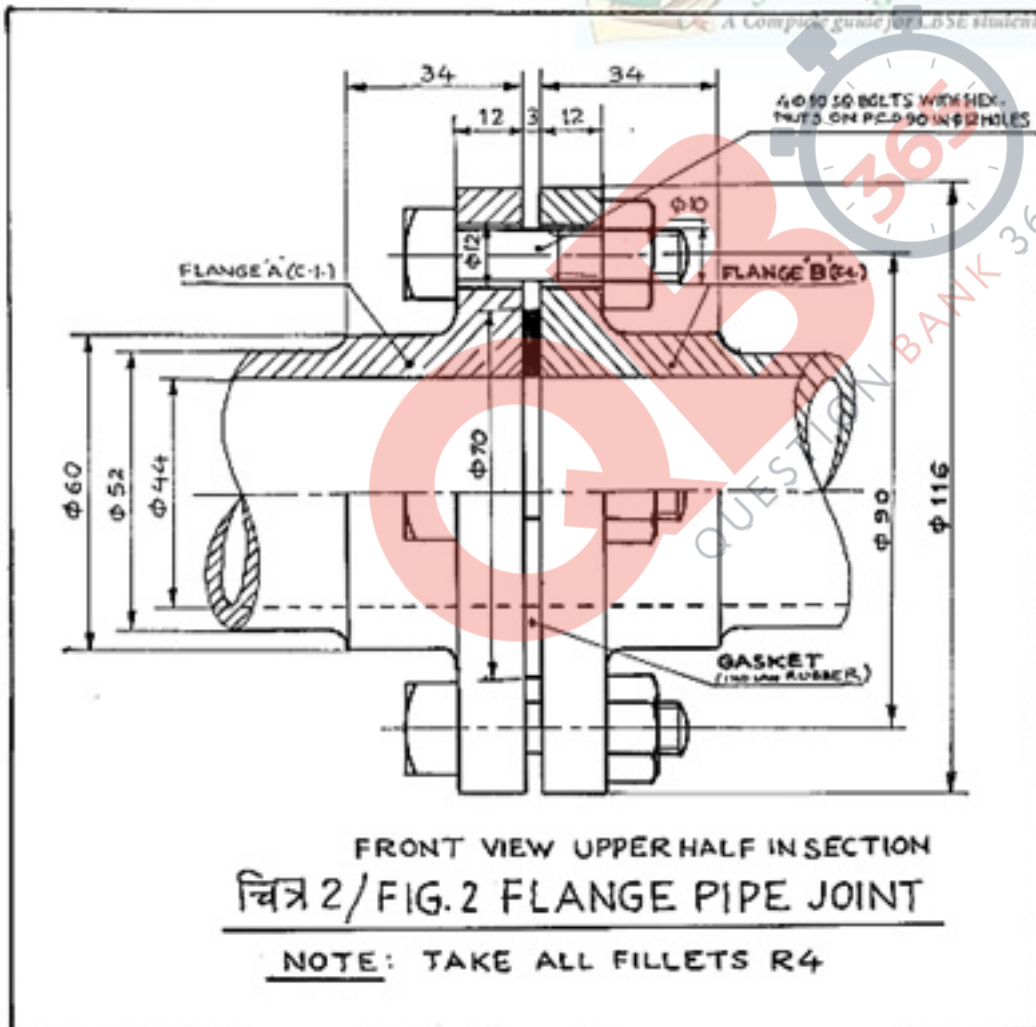

Ans. SLEEVE AND COTTER JOINT (Assembly)

(i) FRONT VIEW (Upper Half in Section) :

(a) Sleeve in upper half, clearances, hatching lines.

(b) Rods with broken section around cotter in upper half, clearances, chamfered ends and broken ends as per convention.

(c) Cotters in upper half.

(d) Sleeve, rods and cotters in lower half.

(ii) SIDE VIEW (Viewed from right side):

(a) Four circles. (b) Cotter. (c) Hatching as per convention. (d) Cutting plane. $\frac{1}{2}$

DETAILS : 6

Printing title(1), scale used(1), drawing projection symbol(1) and six dimensions(3).

[OR]

FLANGE PIPE JOINT (Dis-assembly)

1) FLANGE B:

(i) FRONT VIEW (Upper Half in Section) :

(a) Flange in upper half(2), hole for bolt(1), broken end as per convention(1), hatching(1).

(b) Flange in lower half.

(ii) SIDE VIEW (Viewed from right side) :

(a) Four circles(4), one pitch circle diameter(1/2). (b) Drawing four holes for bolt. (c) Hatching as per convention. (d) Cutting plane.

2) GASKET

(i) FRONT VIEW (Full in Section):

(a) Boundry with two horizontal lines. (b) Shading for rubber.

(ii) SIDE VIEW (Viewed from left side) :

(a) Two circles. (b) Cutting plane.

DETAILS :

Printing titles of both (1), scale used (1), drawing projection symbol (1) and six dimensions (3).

