

**CBSE
Class X Science
Board Paper – 2013 (Set 2)
Term II**

Total time: 3 hrs

Total marks: 90

General instructions:

1. The question paper comprises of **two sections, A and B**. You are to attempt both the sections.
 2. There is no overall choice. However, internal choice has been provided in all the five questions of five marks category. Only one option in such question is to be attempted.
 3. All the questions of **Section-A** and **Section-B** are to be attempted separately.
 4. Question numbers **1 to 3** in **Section - A** are **one mark** questions. These are to be answered in one word or one sentence.
 5. Question numbers **4 to 7** in **section - A** are **two marks** questions, to be answered in about **30 words each**.
 6. Question number **8 to 19** in **section-A** are **three marks** questions, to be answered in about **50 words**.
 7. Question number **20 to 24** in **section-A** are **five marks** questions, to be answered in about **70 words**.
 8. Question numbers **25 to 42** in **section-B** are multiple choice questions based on practical skills. Each question is a one mark question. You are to select one most appropriate response out of the four provided to you.
-

SECTION - A

1. Whenever there is relative motion between a magnet and a coil, a current is induced in the coil. Name this phenomenon? [1]
2. Name the major parts of the brain. [1]
3. Mention the limitations in exploiting geothermal energy. [1]
4. What type of a reaction is respiration? Explain the process of respiration with the help of a chemical equation. [2]
5. Giving a chemical equation answer the following [2]
 - (a) What happens when copper is heated in air?
 - (b) What happens when the product obtained in above reaction is heated in hydrogen?

QB365-Question Bank Software

6. Compute the heat generated while transferring 96000 coulombs of charge in one hour through a potential difference of 50 V between two ends of a conductor. Also calculate the power input by the source. [2]
7. An electric bulb is connected to a 220 V generator. The current flowing is 2 A. Find the power of the bulb and resistance of its filament. [2]
8. Zinc is a metal found in the middle of the activity series of metals. In nature, it is found as a carbonate ore, ZnCO_3 . Mention the steps carried out for its extraction from the ore. Support with equations. [3]
9. Answer the following question: [3]
- (a) Are all pure liquids bad conductors of electricity? Justify your answer with one example.
 - (b) Why are ionic compounds always hard?
 - (c) Name the cathode and anode in the electrolytic refining of copper.
10. Giving one example of each, define the following terms: [3]
- i. Corrosion
 - ii. Rancidity
11. Write the chemical equation for the preparation of [3]
- (a) Bleaching powder
 - (b) Plaster of Paris
 - (c) Caustic soda
12. Calculate which one uses more energy, a 250 W TV set in 1 hr or a 1200 W toaster in 10 minutes. (Both are connected to the same source of electricity) [3]
13. An electric kettle of 2 kW works for 2 h daily. Calculate the [3]
- i. energy consumed in S.I. and commercial unit
 - ii. cost of running it in the month of June at the rate of Rs. 3.00 per unit.
14. Why does a current-carrying solenoid, when suspended freely, rest along a particular direction? Explain. [3]
- 15.
- (a) Explain the events which take place during photosynthesis.
 - (b) Which test is carried out to prove the presence of starch in leaves? [3]
16. Name the products formed after complete digestion of carbohydrates, proteins and fats in the small intestine. [3]

17. Give reasons: [3]
- i.
 - (a) Pituitary is often termed as master endocrine gland.
 - (b) Pancreas helps in digestion and also regulates blood sugar level.
 - (c) Adrenals are known as emergency glands.
 - ii. Name the part of the hind brain which controls involuntary actions.
18. List any three ways in which construction of dams for production of electricity adversely affects the environment of that place. [3]
19. Aditya suggests to his family to install a solar water heater at their residence. But some family members were in a favour of installing an electric geyser. [3]
- (a) Who according to you is taking a correct decision? Mention the value exhibited by Aditya.
 - (b) Also give reasons (at least 2) for your answer.
- 20.
- (a) Acids as well as bases ionise in water. Name the ions produced by each in water.
 - (b) If we have hydrochloric acid and acetic acid of equal concentration, which will be a stronger acid and why?
 - (c) How will the concentration of hydrogen ions be affected if an acid is diluted? [5]
21. Explain the following: [5]
- (a) Metals like Na, Ca and Mg are never found in a free state in nature.
 - (b) Solder is used for welding electrical circuits.
 - (c) Silver ornaments turn blackish after some time.
 - (d) Gold is used for making jewellery.
 - (e) Gallium will melt if you keep it on your palm.

22. Study the following circuit and answer the questions that follow.

[5]

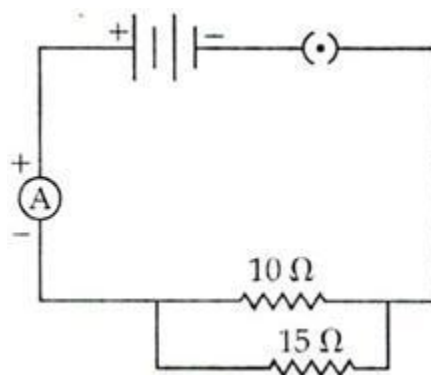

- (a) State the type of combination of the two resistors in the circuit.
- (b) How much current is flowing through the
 - i. 10 ohm resistor
 - ii. 15 ohm resistor
- (c) What is the ammeter reading?
- (d) Define the S.I. unit of current.

23.

- (a) What is an electric circuit?
- (b) Calculate the number of electrons that flow per second to constitute a current of one ampere. Charge on an electron is $1.6 \times 10^{-19}\text{C}$.
- (c) Draw an electric circuit for studying Ohm's law. Label the circuit component used to measure electric current and potential difference. [5]

24.

- (a) Write three main steps which take place in the chloroplast during photosynthesis.
- (b) How do stomata open and close?
- (c) Which raw material is made available to plants for photosynthesis when stomata are open? [5]

SECTION-B

25. A drop of colourless liquid is poured over blue litmus paper and it turns to red. The colourless liquid is [1]
(a) Potassium hydroxide solution
(b) Sodium chloride solution
(c) Pure water
(d) Dilute hydrochloric acid
26. A student uses lime water to test the gas evolved as a result of action of dilute HCl on solid sodium carbonate. The chemical compound present in lime water is [1]
(a) Calcium chloride
(b) Calcium sulphate
(c) Calcium nitrate
(d) Calcium hydroxide
27. A student heated ferrous sulphate crystals in a test tube. He would observe that [1]
(a) The crystals start melting
(b) The crystals evaporate
(c) A very pungent gas is given out
(d) The crystals catch fire
28. The action of water on quicklime is classified as a combination reaction as [1]
(a) A precipitate is formed.
(b) Only one product is formed
(c) Heat is evolved.
(d) Sound and heat are evolved
29. Name the precipitate formed when aqueous solutions of sodium sulphate and barium chloride are mixed. [1]
(a) Barium sulphide
(b) Barium hydroxide
(c) Sodium chloride
(d) Barium sulphate

- 30.** Aradhita added zinc granules in an iron sulphate solution and made a few observations. Identify the incorrect observation. [1]
- i. Pale green solution becomes colourless
 - ii. Black deposit seen on zinc granules
 - iii. Red deposit seen on zinc granules
 - iv. Colourless solution becomes pale green
- (a) i. and ii.
 - (b) iii. and iv.
 - (c) ii. and iii.
 - (d) i. and iv.
- 31.** The precautions to be taken while performing the experiment for testing the reactivity of metals are [1]
- (a) Use the same piece of metal in each test tube.
 - (b) Clean each metal piece with sand paper before use.
 - (c) Use the same test tube for all the solutions.
 - (d) Use the chemicals in excess to get good results.
- 32.** A voltmeter had graduations 0, 0.5, 1.0, 1.5, 2.0 and 2.5. A student noticed that the pointer of the voltmeter was indicating the third graduation mark after 0 mark even when the circuit was open. The space between 2.0 and 2.5 was divided into 10 equal divisions. The zero error in the voltmeter was [1]
- (a) + 0.3 V
 - (b) + 0.15 V
 - (c) -0.15 V
 - (d) -0.3 V
- 33.** In a voltmeter there are 20 divisions between the 0 mark and 0.5 V mark. The least count of the voltmeter is [1]
- (a) 0.020 V
 - (b) 0.025 V
 - (c) 0.50 V
 - (d) 0.250 V
- 34.** The potential difference which is required to cause 4.00 A current to flow through a resistor of $330\ \Omega$ is [1]
- (a) 334 V
 - (b) 12.1 V
 - (c) 1320 V
 - (d) 82.5 V

35. To find the equivalent resistance of two resistors R_1 and R_2 connected in series, Rahul prepared a circuit as shown below. Another student Mohit observed the circuit and said that the circuit is not correct. The mistake in the circuit is [1]

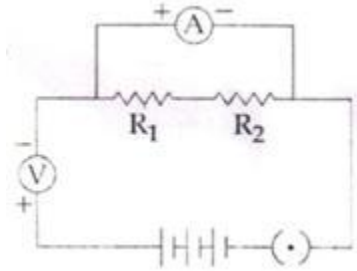

- (a) The two resistors and the ammeter have been connected correctly but not the voltmeter.
(b) The two resistors, the voltmeter and the ammeter all have been connected correctly.
(c) The two resistors have been connected correctly but not the voltmeter and the ammeter.
(d) The two resistors and the voltmeter have been connected correctly but not the ammeter.
36. A student joined three resistances as shown in the circuit below. The current recorded by the ammeter (A) is: [1]

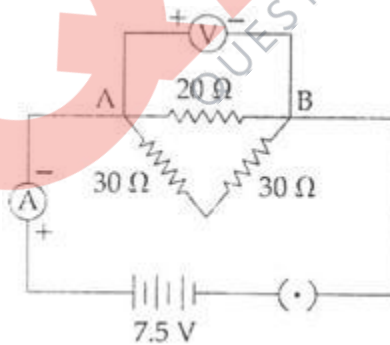

- (a) 0.25 A
(b) 0.5 A
(c) 0.75 A
(d) 1 A

37. In the following sketch of the stomata the parts I, II, III and IV were labeled differently by four students: [1]

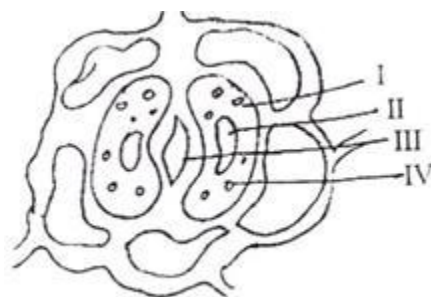

The correct labeling, out of the following is

- (a) I - Guard cell, II - stomata, III - starch granule, IV - nucleus
 - (b) I - Cytoplasm, II - chloroplast, III - stomata, IV - nucleus
 - (c) I - Guard cell, II - starch, III - nucleus, IV - stomata
 - (d) I - Cytoplasm, II - nucleus, III - stomata, IV - chloroplast
38. A student had drawn the diagram of stomata from the temporary stained mount of leaf peel. Below are given some corrections needed in the diagram. [1]
- (a) Shape of guard cells needs correction.
 - (b) Epidermal cells should have one nucleus only.
 - (c) Chloroplasts should be drawn in the guard cells.
 - (d) More nuclei are to be drawn in the guard cells.

Actually needed corrections in the diagram are:

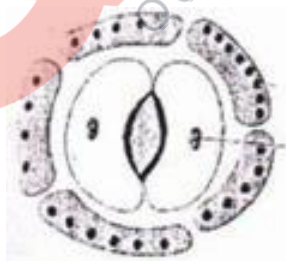

- (a) A and B
- (b) A, B and C
- (c) A and D
- (d) B and C

39. To get result as shown in Fig.2, the leaf should be covered on: [1]

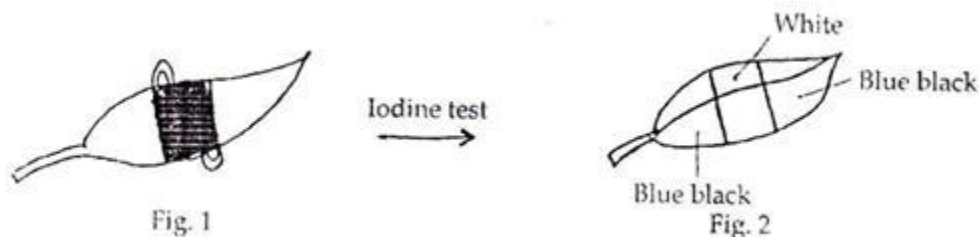

- (a) Upper side
- (b) Lower side
- (c) Partially covered on both sides
- (d) Both sides

40. At very high intensities, green plants show [1]

- (a) High rate of photosynthesis
- (b) High rate of respiration
- (c) Low rate of respiration
- (d) Low rate of photosynthesis

41. A student while setting up the experiment to show that CO₂ is evolved during respiration committed some errors shown in the figure. [1]



The changes which should be made in the set up to get the desired results is

- (a) KOH should be taken in the small test tube inside the flask and germinating seeds in beaker.
- (b) Water should be taken in the beaker and KOH solution in the flask.
- (c) Water should be taken in the flask and KOH solution in the small test tube.
- (d) KOH solution should be taken in the small test tube inside the flask and water should be taken in the beaker.

42. In the experiment to show that CO₂ is released during respiration, the solution in the test tube is chemically: [1]

- (a) NaOH
- (b) NaCl
- (c) KCl
- (d) KOH

**CBSE
Class X Science
Board Paper – 2013 (Set 2) Solution
Term II**

SECTION-A

1. Whenever there is relative motion between a magnet and a coil, a current is induced in the coil. This phenomenon is called Electromagnetic Induction.
2. The brain is divided into three regions: forebrain, midbrain and hindbrain.
3. The limitations in exploiting geothermal energy are,
 - i. It is not available everywhere.
 - ii. Deep drilling into Earth to obtain geothermal energy is technically very difficult and expensive.

4. Cellular respiration is a redox reaction.

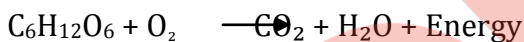
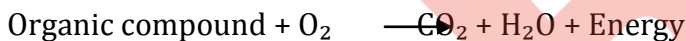

- 5.

(a) When copper is heated in air, it reacts with the oxygen in air to form a black compound copper oxide.

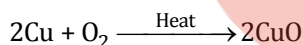

(b) When copper oxide formed in the above reaction is heated in hydrogen, the copper oxide is reduced and brown copper metal is obtained.

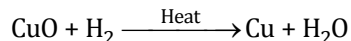

6. Given:

$$Q = 96000 \text{ C}$$

$$t = 1 \text{ hr} = 60 \times 60 = 3600 \text{ s}$$

$$I = \frac{Q}{t} = \frac{96000}{3600} = \frac{80}{3} \text{ A} = 26.67 \text{ A}$$

$$\text{Given: } V = 50 \text{ V}$$

Amount of heat generated is

$$H = V \times I \times t$$

$$= 50 \times 26.67 \times 3600$$

$$H = 4800000 \text{ J}$$

$$H = 4.8 \times 10^6 \text{ J}$$

Power input by the source is

$$P = VI$$

$$P = 50 \times 26.67 = 1333.5 \text{ W}$$

7. Given:

$$V = 220 \text{ V}$$

$$I = 2 \text{ A}$$

To calculate Power,

$$P = VI$$

$$= 220 \times 2$$

$$P = 440 \text{ W}$$

The power of the bulb is 440 W.

To calculate Resistance,

$$R = \frac{V}{I}$$

$$R = \frac{220}{2} = 110 \Omega$$

Resistance of the filament is 110Ω.

8. The metals found in the middle of the reactivity series are extracted by the reduction of their oxides with carbon. So, in order to extract zinc metal from zinc carbonate, zinc carbonate is first converted into zinc oxide. Zinc carbonate (calamine ore) is heated strongly in the absence of air to obtain zinc oxide and carbon dioxide. This process is called calcination.

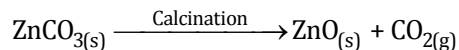

The moderately reactive metal zinc is extracted from its oxide by using a reducing agent like carbon. Zinc oxide is mixed with carbon (in the form of coke) and heated in a furnace. Carbon reduces the metal oxide to free zinc metal.

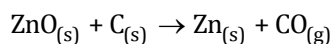

9.

- (a) No. All pure liquids are not bad conductors of electricity. There are many pure liquids which are good conductors of electricity. For example, solutions of acids like sulphuric acid, nitric acid are good conductors of electricity.
- (b) Ionic compounds are hard solids because their oppositely charged ions attract one another strongly and form a regular crystal structure.
- (c) Cathode: A thin strip of pure copper metal.
Anode: A thick block of impure copper metal

10.

- i. The eating up of metals by the action of air, moisture or a chemical (such as an acid) on their surface is called corrosion. For example, when an iron object is left in damp air (or water) for a considerable time, it gets covered with a red-brown flaky substance called rust. This is called rusting of iron.
- ii. The condition produced by aerial oxidation of fats and oils in foods, marked by unpleasant smell and taste is called rancidity. It spoils the food materials prepared in fats and oils which have been kept for a considerable time and makes them unfit for eating. For example, Potato chips are made in oil. On exposing them for a long time, these chips start giving unpleasant smell and taste. They turn rancid.

11.

(a) Bleaching powder:

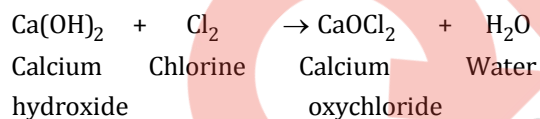

(b) Plaster of Paris:

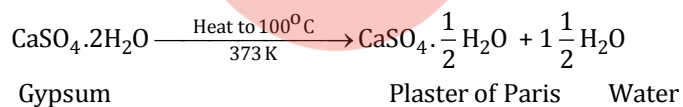

(c) Caustic soda:

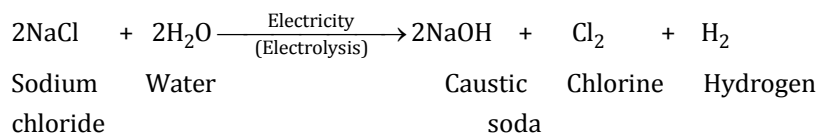

12. We know that,

$$\text{Energy consumed (E)} = \text{Power (P)} \times \text{Time (t)}$$

For TV set:

$$P = 250 \text{ W}$$

$$t = 1 \text{ hr} = 60 \times 60 = 3600 \text{ s}$$

$$E = P \times t$$

$$E = 250 \times 3600$$

$$E = 9 \times 10^5 \text{ J}$$

For toaster:

$$P = 1200 \text{ W}$$

$$T = 10 \text{ min} = 10 \times 60 = 600 \text{ s}$$

$$E = P \times t$$

$$E = 1200 \times 600$$

$$E = 7.2 \times 10^5 \text{ J}$$

∴ A 250 W TV set in 1 hr consumes more energy than a 1200 W toaster in 10 minutes.

13. Given:

$$P = 2 \text{ kW} = 2000 \text{ W}$$

$$t = 2 \text{ hr} = (2 \times 60 \times 60) \text{ s} = 7200 \text{ s}$$

i. $E = P \times t$

$$E = 2000 \times 7200$$

$$E = 1.44 \times 10^7 \text{ J (in S.I. unit)}$$

$$E = P \times t$$

$$E = 2 \text{ kW} \times 2 \text{ h}$$

$$E = 4 \text{ kWh (in commercial unit)}$$

ii. Energy consumed in 1 day = 4 kWh

$$\text{Energy consumed in 30 days} = 4 \times 30 = 120 \text{ kWh}$$

$$\therefore \text{No. of units consumed in 30 days} = 120$$

$$\text{Cost of 1 unit} = \text{Rs. } 3$$

$$\text{Cost of 120 units} = 3 \times 120 = \text{Rs. } 360$$

14. A current-carrying solenoid behaves like a bar magnet. We know that a freely suspended bar magnet aligns itself in the north-south direction. So, a freely suspended current-carrying solenoid also aligns itself in the north-south direction.

15.

(a) Photosynthesis takes place in the following three steps:

- i. Absorption of sunlight energy by chlorophyll.
- ii. Conversion of light energy into chemical energy, and splitting of water into hydrogen and oxygen by light energy.
- iii. Reduction of carbon dioxide by hydrogen to form carbohydrate like glucose by utilizing the chemical energy.

(b) Iodine test is done to prove the presence of starch in leaves. The starch present in leaves gives blue-black colour with iodine solution.

16. In small intestines, the intestinal juice contains a number of enzymes which complete the digestion process by converting complex carbohydrates into glucose, proteins into amino acids and fats into fatty acids and glycerol.

17.

i.

(a) Pituitary gland is often termed as the Master gland because it controls the secretion of all other endocrine glands.

(b) Pancreas secretes digestive enzymes which help in digestion and the hormone insulin regulates blood sugar level.

(c) During emergency conditions, when a person is excited or frightened, adrenal gland secretes adrenaline hormone in large amounts which prepares our body for action. It speeds up our heart beat and breathing, raises blood pressure and allows increased glucose to be absorbed into the blood to give more energy. Hence, it is often known as emergency glands.

ii. Medulla controls various involuntary actions such as heart beat, blood pressure, etc.

18. The construction of dams for production of electricity adversely affects the environment of the place in the following ways:

- i. Large areas of agricultural land and human habitation are to be sacrificed as they get submerged.
- ii. Large eco-systems are destroyed when submerged under water in dams.
- iii. The vegetation which is submerged, rots under anaerobic conditions and gives rise to large amounts of methane which is a green-house gas.

19.

(a) Aditya is taking a correct decision. Values exhibited by Aditya are:

- i. Social Awareness
- ii. Concern for the environment

(b) Solar water heater is a better choice than electric geyser because:

- i. Sun is a renewable source of energy.
- ii. Power source of the Sun is absolutely free.

20.

- (a) Acids ionise in water to produce positively charged hydrogen ions (H^+). Bases ionise in water to produce negatively charged hydroxide ions (OH^-).
- (b) Hydrochloric acid will be a stronger acid than acetic acid because it completely ionises in water to produce a large amount of hydrogen ions. On the other hand, acetic acid partially ionises in water to produce only a small amount of hydrogen ions.
- (c) The concentration of hydrogen ions decreases if an acid is diluted by adding more and more water to it.

21.

- (a) Metals like Na, Ca and Mg are very reactive metals and react with oxygen even at room temperature, therefore they are never found in the free state in nature.
- (b) Solder is an alloy which has a low melting point. Hence it is used for welding electrical circuits.
- (c) Silver ornaments turn blackish after some time due to the formation of a thin silver sulphide layer on their surface by the action of hydrogen sulphide gas present in air.
- (d) Gold is used for making jewellery because of its bright shiny surface and high resistance to corrosion.
- (e) Gallium has a very low melting point ($28^\circ C$) and starts melting when kept on our hand due to the heat of our body.

22.

- (a) Parallel combination.
- (b) Let V be the voltage applied.
 - i. Current flowing through 10Ω resistor is

$$I_1 = \frac{V}{R_1} = \frac{V}{10} \text{ A}$$

- ii. Current flowing through 15Ω resistor is

$$I_2 = \frac{V}{R_2} = \frac{V}{15} \text{ A}$$

- (c) Equivalent resistance of the circuit, R is given as

$$\frac{1}{R} = \frac{1}{R_1} + \frac{1}{R_2}$$

$$\frac{1}{R} = \frac{1}{10} + \frac{1}{15}$$

$$\frac{1}{R} = \frac{1}{6}$$

$$R = 6 \Omega$$

$$\text{Ammeter reading, } I = \frac{V}{R} = \frac{V}{6} \text{ A}$$

(d) S.I. unit of current is ampere.

Definition of ampere: When 1 coulomb of charge flows through any cross-section of a conductor in 1 second, then current flowing through it is said to be 1 ampere.

$$1 \text{ ampere} = \frac{1 \text{ coulomb}}{1 \text{ second}}$$

23.

(a) A continuous conducting path consisting of wires and other resistances (like electric bulb, etc.) and a switch, between the two terminals of a cell or a battery along which an electric current flows, is called an electric circuit.

(b) Given:

$$I = 1 \text{ A}$$

$$t = 1 \text{ sec}$$

$$I = \frac{Q}{t}$$

$$I = \frac{Q}{1}$$

$$Q = 1 \text{ C}$$

$1.6 \times 10^{-19} \text{ C}$ is the charge on 1 electron.

1 C is the charge on $\frac{1}{1.6 \times 10^{-19}}$ electrons = (6.25×10^{18}) electrons.

6.25×10^{18} electrons flow per second to constitute current of one ampere.

(c)

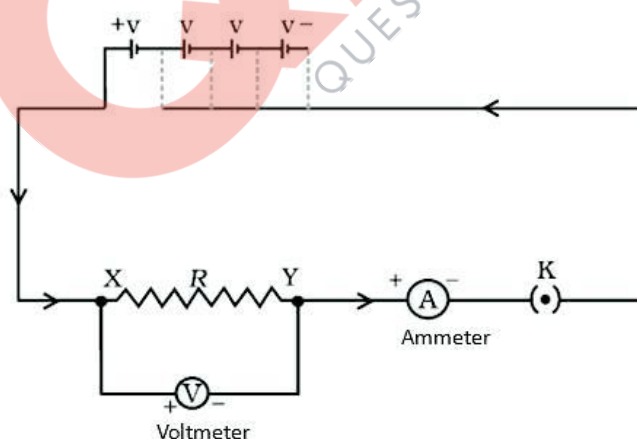

Electric circuit for studying Ohm's law

24.

- (a) The steps which take place inside the chloroplast during photosynthesis are
- i. Absorption of sunlight energy by chlorophyll.
 - ii. Conversion of light energy into chemical energy, and splitting of water into hydrogen and oxygen by light energy.
 - iii. Reduction of carbon dioxide by hydrogen to form carbohydrates like glucose by utilizing the chemical energy.
- (b) The opening and closing of stomata is controlled by guard cells. When water flows into the guard cells, they swell, become curved and cause the stomata to open. When the guard cells lose water, they shrink, become straight and the stomata is closed.
- (c) Carbon dioxide is made available to plants when stomata are open.

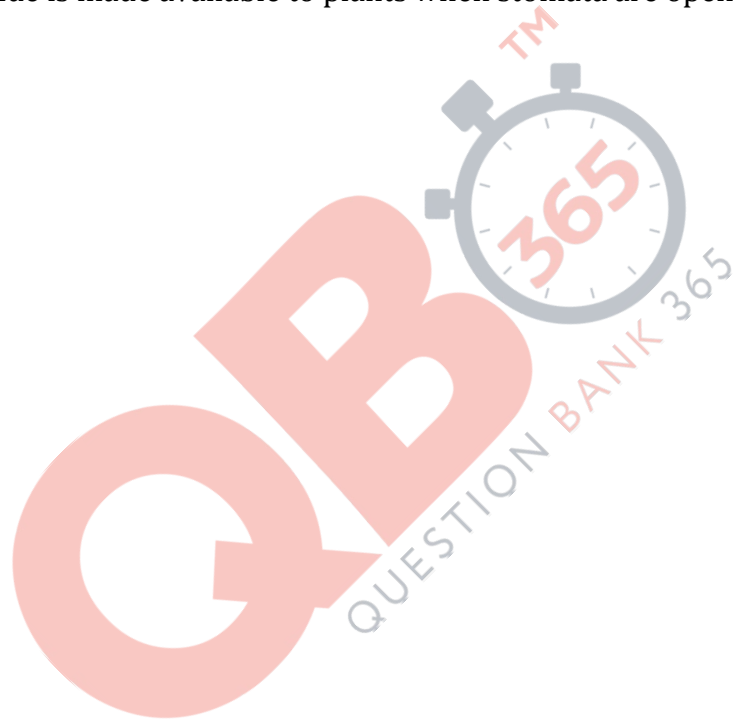

SECTION-B

25. (d) Dilute hydrochloric acid

Acids turn blue litmus to red hence dilute hydrochloric acid turns blue litmus paper red.

26. (d) Calcium hydroxide

Lime water is calcium hydroxide solution.

27. (c) Very pungent gas is given out.

When ferrous sulphate crystals are heated in a test tube, pungent smell of burning sulphur is obtained due to formation of sulphur dioxide gas.

28. (b) Only one product is formed.

Action of water on quicklime is classified as a combination reaction because they combine to form a single compound, calcium hydroxide.

29. (d) Barium sulphate

When aqueous solutions of sodium sulphate and barium chloride are mixed, then a white ppt. of barium sulphate is formed.

30. (b) iii. and iv.

iii. and iv. are incorrect observations.

A black not red deposit is seen on the zinc granules.

Pale green solution of iron sulphate turns colorless.

31. (b) Clean each metal piece with sand paper before use.

Each metal piece should be cleaned with sand paper before use to remove impurities and dust particles stuck on the surface of the metal.

32. (b) +0.15 V

Difference between the graduations 2.5V and 2V = 0.5V

There are 10 equal divisions between 2V and 2.5V.

So, each division corresponds to $\frac{0.5}{10} = 0.05V$

In an open circuit, the pointer is at third graduation.

Therefore, zero error = $0.05 \times (+3) = +0.15 V$

33. (b) 0.025 V

Least count = $\frac{0.5 - 0}{20} = 0.025 V$

34.(c) 1320 V

$$V = IR$$

$$V = 4.00 \times 330$$

$$V = 1320 \text{ V}$$

35.(c) The two resistors have been connected correctly but not the voltmeter and the ammeter.

The ammeter must be connected in series between the battery and the series combination of the two resistors, and the voltmeter should be connected in parallel across the series combination of the two resistors.

36.(b) 0.5 A

The series combination of two 30Ω resistor is joined in parallel with 20Ω resistance.

Equivalent resistance is given as

$$\frac{1}{R} = \frac{1}{20} + \left(\frac{1}{30 + 30} \right)$$

$$\frac{1}{R} = \frac{1}{20} + \frac{1}{60} = \frac{1}{15}$$

$$R = 15 \Omega$$

$$I = \frac{V}{R} = \frac{7.5}{15} = 0.5 \text{ A}$$

37.(d) I - Cytoplasm, II - nucleus, III - stomata, IV - chloroplast

The correct labeling is I - Cytoplasm, II - Nucleus, III - Stomata, IV - Chloroplast

38.(d) B and C

Epidermal cells should have one nucleus only and chloroplasts should be drawn in the guard cells.

39.(d) both sides

The leaf should be covered on both sides.

40.(d) Low rate of photosynthesis

At very high light intensities, green plants show low rate of photosynthesis because the enzymes for photosynthesis gets denatured at high temperature.

41.(d) KOH solution should be taken in the small test tube inside the flask and water should be taken in the beaker.

42.(d) KOH

KOH solution is used in the experiment to show that CO_2 is released during respiration.