

**CBSE Board
Class X Science
Board Paper – 2009**

Time: 2½ hrs

Total Marks: 60

General Instructions:

1. The question paper comprises of **two Sections, A and B**. You are to attempt both the Sections.
2. **All** questions are **compulsory**.
3. There is no overall choice. However, internal choice has been provided in some questions. Only one option in such questions is to be attempted.
4. All questions of **Section A** and all questions of **Section B** are to be attempted separately.
5. Questions number **1 to 6 in Section A** and **17 to 19 in Section B** are short answer questions. These questions carry **one mark each**.
6. Questions number **7 to 10 in Section A** and **20 to 24 in Section B** are short answer questions and carry **two marks each**.
7. Questions numbers **11 to 14 in Section A** and **25 and 26 in Section B** are also short answer questions and carry **three marks each**.
8. Question numbers **15 and 16 in Section A** and **27 in Section B** are long answer questions and carry **five marks each**.

SECTION-A

Q1. Balance the following chemical equation.

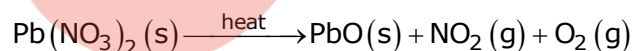

- Q2. Fresh milk has a pH of 6. When it changes into curd (yogurt) will its pH value increase or decrease? Why?
- Q3. Name a reducing agent that may be used to obtain manganese from manganese dioxide.
- Q4. Why does a ray of light bend when it travels from one medium into another?
- Q5. Draw the given diagram in your answer book and complete it for the path of ray of light beyond the lens.

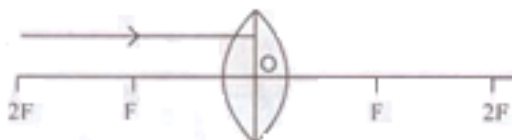

QB365-Question Bank Software

- Q6. Why does sky look blue on a clear day?
- Q7. A compound which is prepared from gypsum has the property of hardening when mixed with a proper quantity of water. Identify the compound. Write the chemical equation for its preparation. For what purpose is it used in hospitals?
- Q8.
- (a) What is the colour of ferrous sulphate crystals? How does this colour change after heating?
 - (b) Name: the products formed on strongly heating ferrous sulphate crystals. What type of chemical reaction occurs in this change?
- Q9. What is the minimum number of rays required for locating the image formed by a concave mirror for an object? Draw a ray diagram to show the formation of a virtual image by a concave mirror.
- Q10. A piece of wire of resistance $20\ \Omega$ is drawn out so that its length is increased to twice its original length. Calculate the resistance of the wire in the new situation.
- Q11. What is meant by 'rusting'? With labeled diagrams, describe an activity to find out the conditions under which iron rusts.
- Q12. Give reasons for the following observations:
- (a) The element carbon forms a very large number of compounds.
 - (b) Air holes of a gas burner have to be adjusted when the heated vessels get blackened by the flame.
 - (c) Use of synthetic detergents causes pollution of water.
- Q13. What is hypermetropia? State the two causes of hypermetropia. With the help of ray diagrams, show:
- i. the eye-defect hypermetropia
 - ii. correction of hypermetropia by using a lens
- Q14. Two resistors, with resistances $5\ \Omega$ and $10\ \Omega$ respectively are to be connected to a battery of emf $6\ \text{V}$ so as to obtain:
- (a) How will you connect the resistances in each case?
 - (i) minimum current flowing (ii) maximum current flowing
 - (b) Calculate the strength of the total current in the circuit in the two cases.

Q15.

- (a) Which two criteria did Mendeleev use to classify the elements in his periodic table?
- (b) State Mendeleev's periodic law.
- (c) Why could no fixed position be given to hydrogen in Mendeleev's periodic table?
- (d) How and why does the atomic size vary as you go:
 - i) From left to right along a period?
 - ii) Down a group?

OR

- (a) Why did Mendeleev have gaps in his periodic table?
- (b) State any three limitations of Mendeleev's classification.
- (c) How do electronic configurations of atoms change in a period with increase in atomic number?

Q16.

- (a) What is a magnetic field? How can the direction of magnetic field lines at a place be determined?
- (b) State the rule for the direction of the magnetic field produced around a current carrying conductor. Draw sketch of the pattern of field lines due to a current flowing through a straight conductor.

OR

- (a) What is a solenoid? Draw a sketch of the pattern of field lines of the magnetic field through and around a current carrying solenoid.
- (b) Consider a circular loop of wire lying in the plane of the table. Let the current pass through the loop clockwise. Apply the right hand rule to find out the direction of the magnetic field inside and outside the loop.

SECTION-B

- Q17. What are the two main components of our environment?
- Q18. What will happen to a plant if its xylem is removed?
- Q19. Name two tissues that provide control and coordination in multi cellular animals.
- Q20. What natural resources? State two factors that work against an equitable distribution of these resources.
- Q21. What is water harvesting? Mention any water harvesting structures.
- Q22. What are 'nastic' and 'curvature' movements? Give one example of each.
- Q23. What is biogas? Why is biogas considered an ideal fuel for domestic use?
- Q24.
- (a) Distinguish between renewable and non-renewable sources of energy.
 - (b) Choose the renewable sources of energy from the following list: Coal, biogas, sun, natural gas
- Q25. Explain analogous organs and homologous organs. Identify the analogous and homologous organs amongst the following:
- Wings of an Insect, wings of a bat, forelimbs of frog, forelimbs of a human
- Q26. (a) Explain the terms:
- i) Implantation
 - ii) Placenta
- (b) What is the average duration of human pregnancy?
- Q27.
- (a) Draw a diagram of human alimentary canal and label on it:
Oesophagus, Gall bladder, Liver and Pancreas
 - (b) Explain the statement, 'Bile does not contain any enzyme but it is essential for digestion'.

OR

QB365-Question Bank Software

- (a) Draw a diagram of excretory system in human beings and label on it:
Aorta, vena cava, urinary, bladder, urethra
- (b) List two vital functions of the kidney.



**CBSE Board
Class X Science
Board Paper – 2009
Solution**

SOLUTION

Time: 2½ hrs

Total Marks: 60

SECTION-A

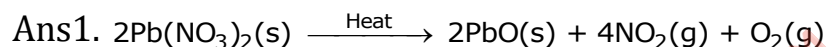

Ans2. pH value decreases when fresh milk changes to curd.

Ans3. Hydrochloric acid may be used as the reducing agent to obtain manganese from manganese dioxide.

Ans4. Light has different speeds in different media and it takes such a path of propagation for which time taken is minimum.

Ans5.

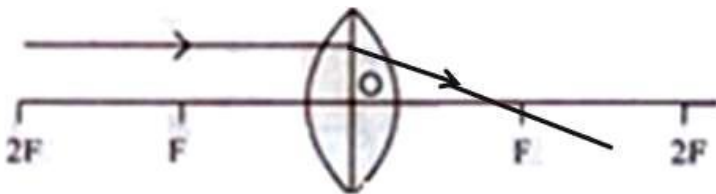

Ans6. Sky looks blue on a clear day because blue colour of light is scattered most by the particles present in the atmosphere.

Ans. Plaster of Paris (Calcium sulphate hemihydrate) $\text{CaSO}_4 \cdot \frac{1}{2}\text{H}_2\text{O}$

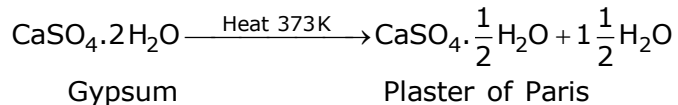

It is used in hospitals as a plaster to support fractured bones in the right position.

Ans8.

- (a) Ferrous sulphate crystals are light green in color. On heating, the green color of the crystals changes to white since its water of crystallisation is removed on heating.
- (b) On strongly heating ferrous sulphate crystals, ferric oxide, sulphur dioxide and sulphur trioxide is formed.

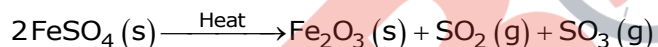

This is a decomposition reaction.

Ans9. At least two rays are required for locating the image formed by a concave mirror for an object. Formation of virtual image by concave mirror:

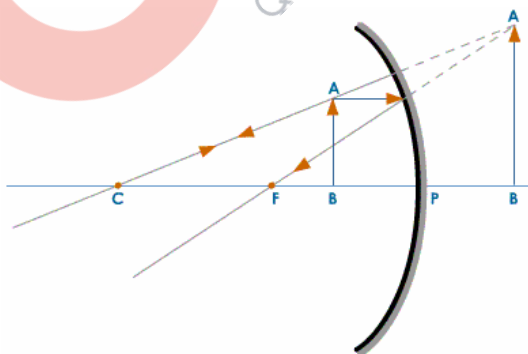

QB365-Question Bank Software

Ans10. $R = \frac{\rho l}{A}$

If the length is increased to twice the original length, keeping the area of cross section same, then resistance will become double of its original value.

So new resistance = $2 \times 20 = 40$ ohm.

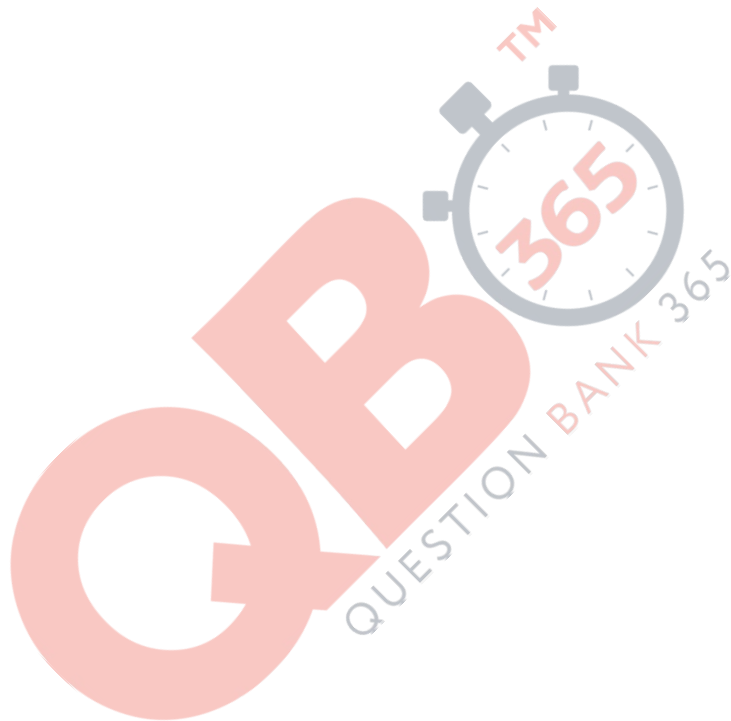

Ans11. Rusting is corrosion of iron to a brown flaky substance in the presence of moist air.

Activity to find out the conditions under which iron rusts:

1. Take three test tubes and place clean iron nails in each of them.
2. Label these test tubes as A, B and C.
3. Pour some water in test tube A and cork it.
4. Pour boiled distilled water in test tube B, add about 1 mL of oil and cork it. The oil will float on water and prevent air from dissolving in water.
5. Put some anhydrous calcium chloride in test tube C and cork it. Anhydrous calcium chloride will absorb the moisture, if any, from the air.
6. Leave the three test tubes for a few days and then observe.

Observation: The iron nails in test tube A rusts. In test tubes B and C, no rusting occurs.

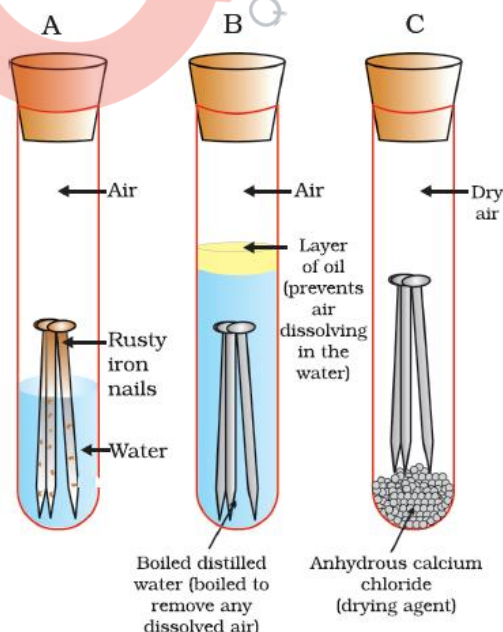

Conclusion: Both air and moisture are necessary for rusting of iron.

Ans12.

- (a) The element Carbon forms a large number of compounds due to its unique properties: catenation and tetravalency.
- (b) If fuel in the gas burner does not burn completely, then incomplete combustion occurs resulting in production of a sooty flame and hence the vessels get blackened from the bottom. So, for sufficient supply of air for complete combustion, the air holes of a gas burner have to be adjusted.
- (c) Synthetic detergents cause pollution because they are non biodegradable in nature.

Ans13. Hypermetropia is an eye defect in which distant vision is clear while near vision is blurred.

Causes of Hypermetropia:

- Shortening of the eyeball, that is, the eyeball becomes smaller
- Increase in focal length of the eye lens

(i)

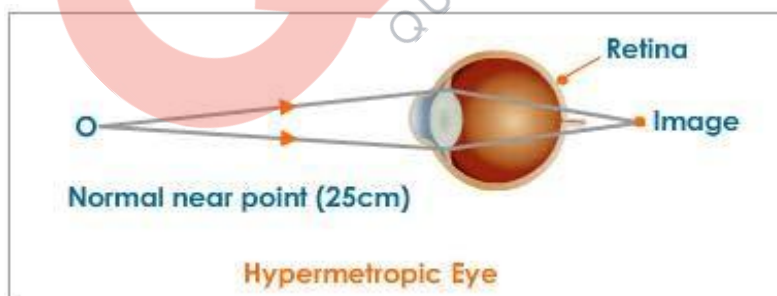

(ii)

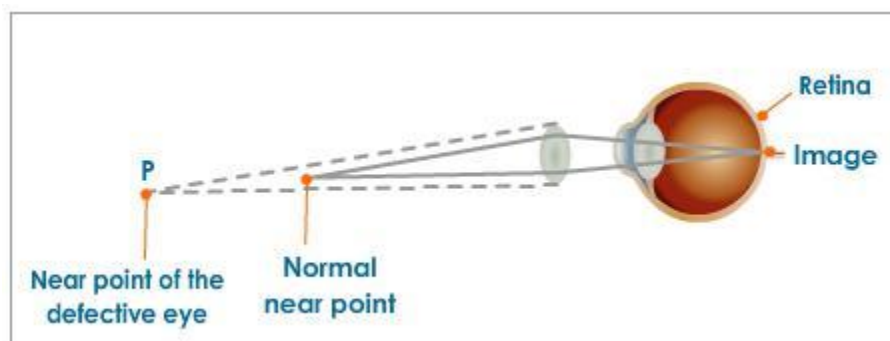

Ans14.

(a)

- (i) To obtain the minimum current, the resistances should be connected in series.
- (ii) To obtain the maximum current, the resistances should be connected in parallel.

(b)

(i) Resistances in series:

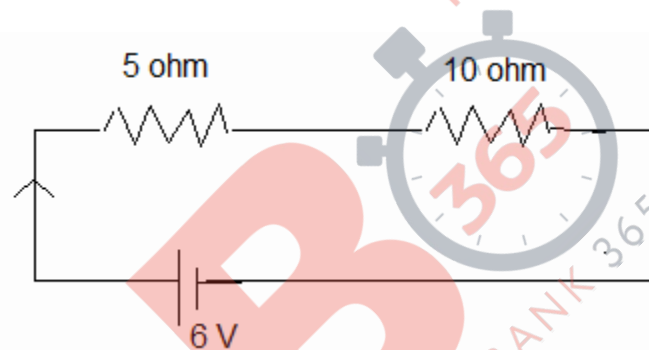

Total resistance in the circuit = $5 + 10 = 15$ ohm

Current in the circuit $I = 6 / 15 = 0.4$ A

(ii) Resistances in parallel:

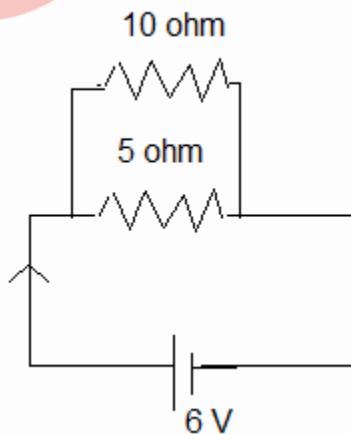

Total resistance in the circuit = $(5 \times 10) / (5 + 10) = 50 / 15 = 10 / 3$ ohm

Current in the circuit $I = 6 \times 3 / 10 = 1.8$ A

Ans15.

- (a) Increasing atomic mass and similarity in chemical properties of elements were the two criteria used by Mendeleev to classify the elements. He took the formulae of the oxides and hydrides formed by the elements as the basis for classification of elements.
- (b) Mendeleev's periodic law states that the properties of elements are periodic function of their atomic masses.
- (c) Hydrogen resembles alkali metals in its electronic configuration and halogens as it also exists as a diatomic molecule and combines with metals and non-metals to form covalent compounds hence it could not be assigned a fixed position in Mendeleev's periodic table.
- (d)
 - (i) Atomic size decreases from left to right in the periodic table due to increase in nuclear charge.
 - (ii) Atomic size increases down the group because new shells are being added as we go down the group.

Ans16.

- (a) Magnetic field is a region near a magnetised body where magnetic forces can be detected. The direction of the magnetic field line at a place is determined by the direction in which a north pole of the compass needle moves inside it.
- (b) Direction of the magnetic field produced around a current carrying conductor is determined by the right hand thumb rule.

According to this rule, if we hold a current-carrying straight conductor in right hand such that the thumb points towards the direction of current, then fingers will wrap around the conductor in the direction of the field lines of the magnetic field. This is also shown in the figure given below:

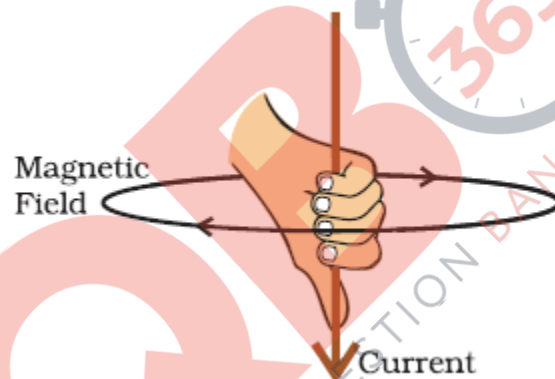

Pattern of field lines due to a current flowing through a straight conductor:

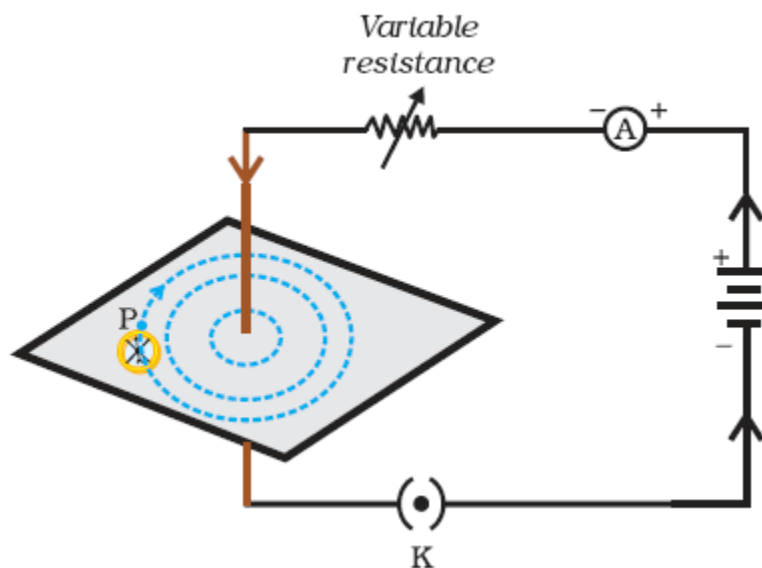

OR

(a) A solenoid is a long coil (shaped like a cylinder) containing a large number of close turns of insulated copper wire.

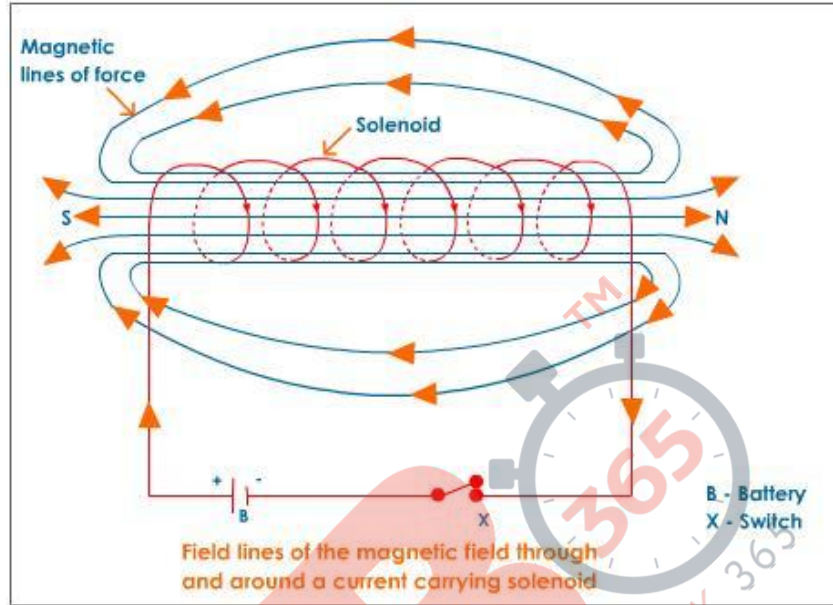

(b) Direction of magnetic field inside and outside the loop is given as follows:

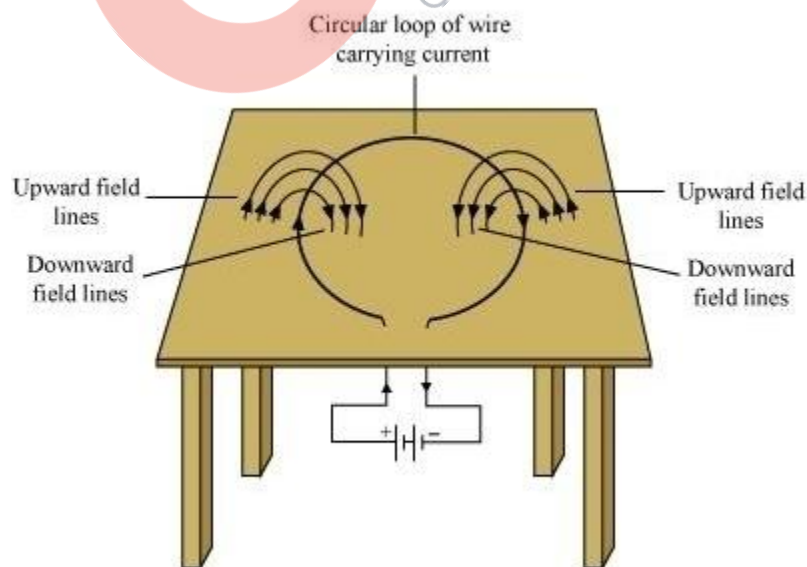

SECTION-B

Ans17. The two main components of our environment are:

- i. Biotic components
- ii. Abiotic components.

Ans18. Xylem tissue conducts water and minerals from the soil to different parts of the plant. If the xylem tissue is removed, then the transport of water and mineral will not take place and the plant will die.

Ans19. Nervous and muscular tissues provide control and coordination in multi cellular animals.

Ans20. Natural resources are naturally occurring substances that are considered valuable in their relatively unmodified or natural form. The examples of such resources are coal, wildlife, oil etc.

Two factors that work against the equitable distribution of these resources are:

- (i) Corruption
- (ii) Lack of proper management

Ans21. Water harvesting is the activity of collecting rainwater for future use. Harvesting of rainwater is essential for ensuring the availability of usable water. The rainwater collected can be stored in surface containers for direct use or can be recharged into the groundwater.

Khadins and Nadis are two traditional water harvesting structures that are found in Rajasthan.

Ans22. Nastic movements are non-directional and growth independent movements that occur in response to stimuli such as light, temperature, humidity, etc.

For example: Touch-me-not plant leaves bend and droop on touching.

Curvature movements are the bending or curving movements of a plant in response to any stimuli.

For example: The bending of the shoot tip towards light.

Ans23. Biogas is the gas made from the anaerobic decomposition of organic matter such as agricultural wastes and animal wastes like animal dung. It is prepared in bio-gas plants. It consists of a methane, carbon dioxide, hydrogen and hydrogen sulphide.

Biogas is considered as an ideal fuel because it:

- (i) It has a high calorific value.
- (ii) It burns without producing smoke.
- (iii) It is a safe and efficient method of waste-disposal.
- (iv) It leaves no residue after burning.

Ans24. (a)

Renewable sources of energy	Non-renewable sources of
i. These are inexhaustible that is can be used over a long time.	i. They are exhaustible and therefore cannot be used over a long time.
ii. They are replenished at a rate faster than the rate at which they are consumed.	ii. The rate at which they are replenished is much slower than the rate of consumption.

(b) Biogas and sun

Ans25.

Analogous organs: These are organs that have different structural design and origin, but perform similar functions.

Homologous organs: These organs have the similar basic structural design and origin, but are evolved to perform different functions.

Analogous organs: Wings of an insect and wings of a bat. Homologous organs: Forelimbs of frog and forelimbs of a human.

Ans26.

(a)

- (i) Implantation is the event during pregnancy in which a fertilized egg or zygote adheres to the walls of the uterus, inside the female body.
- (ii) Placenta is a disc like vascular structure embedded in the uterine wall. The placenta supplies nutrients like glucose and oxygen to the developing embryo. It also removes waste substances generated by the embryo.

(b) The average duration of human pregnancy is nine months.

Ans27. (a)

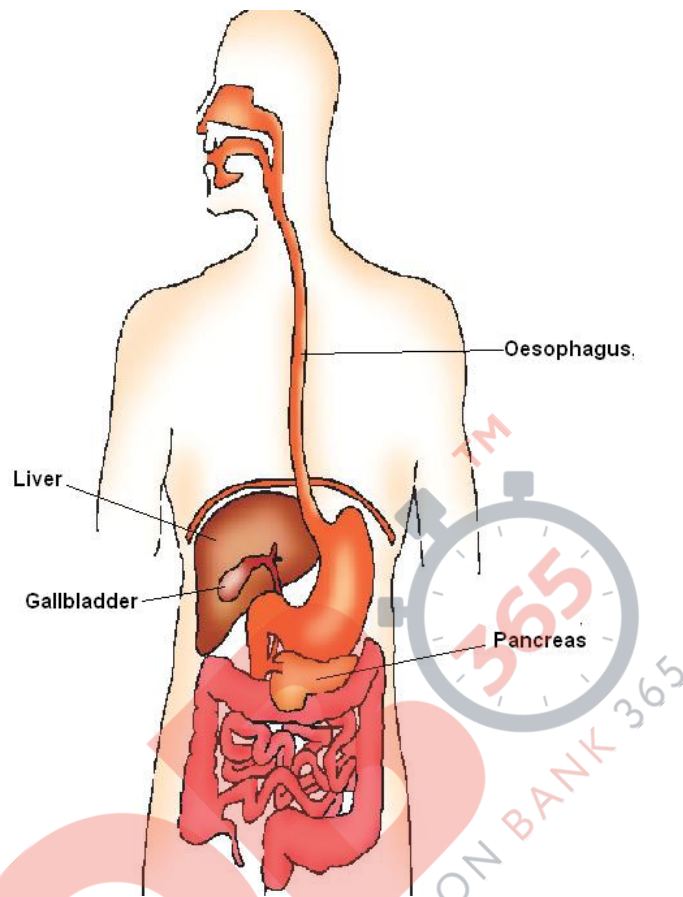

(b) Bile does not contain any enzyme, but it plays an important role in digestion because:

- (i) The bile salts emulsify fat by acting on large fat globules to break them into smaller globules. This increases the efficiency of pancreatic enzymes.
- (ii) The food entering the small intestine is acidic. It is made alkaline by the action of bile juice so as to facilitate the action of pancreatic enzymes.

OR

(a)

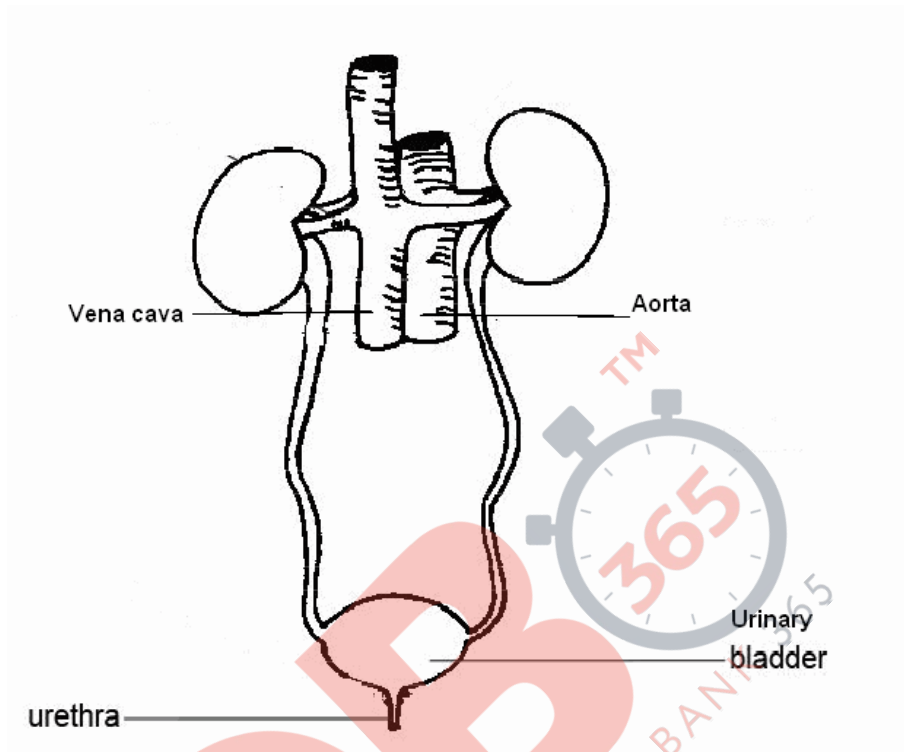

(b) The two vital functions of kidney are:

- (i) It filters out the nitrogenous wastes from the blood and forms urine.
- (ii) It also regulates the water balance and levels of mineral ions in the body.